

Copyright Notice

L2000DX *User's Manual* and other documentation copyright © 1998 and 2001 Dexsil Corporation. All rights reserved.

Disclaimer

Dexsil Corporation makes no representations or warranties with respect to the contents hereof and specifically disclaims any implied warranties of merchantability or fitness for any particular purpose. Further, Dexsil Corporation reserves the right to revise this publication and to make changes from time to time in the contents hereof without obligation of Dexsil Corporation to notify any person of such revision or changes.

Trademarks

L2000 and Dexsil are trademarks of Dexsil Corporation.

DEXSIL CORPORATION

One Hamden Park Drive
Hamden, CT 06517
Tel (203) 288-3509
Fax (203) 248-6523
<http://www.dexsil.com>

Table of Contents

Introduction to the L2000DX Analyzer	1
Sample Preparation	1
Chloride Conversion Reaction	2
Quantification	2
Unpacking	3
List of Components	3
L2000DX Analyzer Carrying Case With Contents	4
List of Reagent Options	4
Option 1 - 40 Oil Tests	4
Option 2 - 20 Soil Tests	5
Option 2a - 20 Soil Tests (Two-Step Procedure)	5
Option 3 - 20 Water Tests	6
Option 4 - 20 Wipe Tests	6
Initial Set Up	7
Restoring the Electrode After Extended Storage	7
Basic Operation of the L2000DX	9
General Information	9
Turning the Analyzer On and Navigating the Operating Program	10
Calibration	10
Blank Determination	12
Analysis	13
Entering Data	14
Special Keys	14
Electrode Check	15
Sample Preparation	16
Oil Samples	16
Soil Samples	16
Standard Procedure for Soil Analysis	17
Two-Step Extraction Procedure for Soil Analysis	18
Water Samples	19
High Range (5-2000 ppm)	19
Low Range (10 ppb - 20 ppm)	19
Wipe Samples	19
The OPTIONS Menu	21
1.) Creating and Editing a Method	21
Blank Subtraction	22
Chlorine Content	23
Size Correction	23
Extraction Efficiency Correction	23
Matrix	24
Units	24

Analyte Label	24
Method Name	24
2.) Header Information	25
Operator ID	25
Customer ID	25
Job ID	25
Location ID	25
Comments	25
3.) Data Management	26
Storing Data	26
Clearing stored Data	26
4.) Printer Options	27
Printing Data Points When Taken	27
Printing Stored Data	27
Printing Header Information	28
Printing Method	28
5.) Date and Time	28
Entering Time	28
Entering Date	28
6.) Diagnostics	28
Checking Electrode Output	28
7.) Upload	28
8.) Set Temp	29
Entering Temperature	29
Accepting Temperature	29
L2000DX Data Manager	30
Introduction	30
Installation	30
Uploading Data	30
Selecting Data	30
Generating a Report	31
Exporting Data	31
Care and Maintenance	32
Changing Paper	32
General Care	33
Electrode Care and Maintenance	34
Trouble Shooting	34
Error Messages	36
Appendix A: Additional Information Available from Dexsil	38
Appendix B: Methods Table	40
Appendix C: Technical Data	42
Appendix D: Program Flow Chart	43

Introduction to the L2000DX Analysis System

Congratulations on your purchase of the L2000DX Analyzer, a versatile analysis system suitable for the analysis of a wide variety of chlorinated organic compounds in a variety of matrices. The basic principle of the L2000DX system is to measure the total organic chlorine content of a sample and equate that to an equivalent concentration of the target or expected analyte. If all of the organic chlorine present is assumed to be derived from the target analyte, then an upper limit is established for the compound in question. (If other organic chlorines are present, in addition to the target analyte, they will be counted as the target analyte.) To accomplish this, all of the organically bound chlorine must be converted into inorganic chloride and the resulting chloride quantified. Once the total chlorine content of the sample is known, a conversion factor is used to convert the chloride concentration into an equivalent concentration of the target analyte. If the contaminant is known, the resulting concentration estimates will accurately correlate with the actual concentration of the analyte in the sample as determined by GC analysis in the lab. If the contaminant is unknown, a conservative or worst case conversion factor is chosen to provide an upper limit for the concentration of the target analyte in the sample.

There are three basic steps involved in the chemical analysis for total halogen by the L2000DX:

- Sample Preparation
- Conversion to Inorganic Chloride
- Quantification

The sample preparation step determines the type of chlorine detected, i.e., organic, inorganic, or total, and is matrix dependent. The sample preparation can be as simple as collecting a transformer oil sample, or can involve the extraction of a soil or water sample. In the case of a wipe sample, the surface is wiped and the wipe-gauze is extracted. The steps involved in the conversion to inorganic chloride reaction and the chloride quantification are the same for all matrices. The steps in the conversion to inorganic chloride involves the reaction of the sample with metallic sodium and the extraction of the resulting chloride into an aqueous buffer system. A chloride specific electrode is used to quantify the extracted chloride. Using stored conversion factors, the chloride value is then converted to an equivalent concentration of analyte.

Sample Preparation

The L2000DX can be used to analyze the following matrices:

- Transformer Oil
- Soil
- Water
- Surface Wipe

Each matrix requires different preparation prior to the conversion reaction step and subsequent quantification. Each of the matrix preparation steps are described in detail under **Sample Preparation**.

The routine analysis of transformer oil requires no sample preparation other than to collect a clean sample without introducing any extraneous sources of chloride into the sample, such as perspiration or road salt. This is important because, for transformer oil, there is no sample cleanup procedures to remove inorganic chloride contamination. Once collected the sample is reacted and the resulting chloride is extracted and quantified.

The chlorine quantified in this case is the total chlorine contained in the sample. Transformer oil is typically free of inorganic chlorine eliminating the need for any sample cleanup procedure. In special cases where transformers have failed due to water contamination or have been removed for service and stored in areas near seawater or road salt, inorganic chloride may cause an elevated reading.

Before a soil sample can be analyzed, the organic contaminants must be extracted using an organic solvent. Because soil samples invariably contain inorganic chlorine, the soil extract is cleaned up to remove all traces of the inorganic chloride. The cleaned extract is then reacted and the resulting chloride is quantified. For soil analyses, therefore, only the organic chlorine content is ever quantified. Extraneous sources of chloride contamination such as road salt or sea salt are **not** detected.

As with soil samples, a water sample must also be extracted prior to final analysis. The ratio of the solvent volume to the sample volume determines the sensitivity of the test. The extract is reacted and the chloride is quantified as above. As with soil samples, only the organic chlorine is quantified in water samples.

Wipe tests require that a specific area be wiped using a hexane-soaked gauze. The gauze is extracted with an organic solvent, reacted, and the chlorine content determined. For wipe samples, the standard procedure eliminates most all inorganic chlorine contamination. Areas with very high surface concentration of salts may need to be prepared differently.

Chloride Conversion Reaction

Once the sample has been prepared, the remaining chloride conversion steps are the same for all sample types. The conversion step is a reaction of the sample with an excess of metallic sodium in the presence of a catalyst to convert the covalently bound organic chlorine into free chloride ions. This reaction of metallic sodium with organo-chlorine compounds is vigorous and goes to completion converting all of the organic chlorine to chloride.

Quantification

Upon the completion of the conversion reaction, the resulting chloride ions are extracted into an aqueous buffer. The chloride content in the final extract/buffer is then quantified using a chloride specific electrode and converted to an equivalent analyte concentration using the conversion factors programed into the

analysis method of the instrument. The conversion factor is made up of the percent chlorine, the sample size multiplier, and the extraction efficiency multiplier. The analyte concentration is determined by first subtracting the blank from the raw chloride reading (except when the Blank Subtraction has been turned off), and the resulting corrected chloride value is multiplied by the size and extraction multipliers and divided by the chloride fraction (percent chlorine divided by 100):

$$[\text{Analyte}] = ([\text{Cl}^-]_{\text{raw}} - [\text{Cl}^-]_{\text{blank}})(\text{size multiplier})(\text{extraction multiplier})/(\text{chlorine fraction})$$

The L2000DX analyzer comes preprogramed with 28 methods providing for analysis of a large number of chloride compounds in most matrices. Correction factors are preprogramed to account for all of the steps necessary to run samples using the standard prepackaged reagents. If the procedures are modified or other analytes are expected, up to 22 custom methods can easily be built.

The operational program of the L2000DX has been designed to provide the most versatile data reduction platform possible for the analysis of chlorinated organic compounds in a variety of matrices. At the same time, the program is easy to use for routine analysis and does not require custom method development. The operating program is divided into an **Analysis Loop** and the **OPTIONS Menu**. Preprogramed methods are available for use in routine analyses and are easily selected from within the **Analysis Loop**. The software automatically cycles back to critical points in the analysis loop to prompt the user for “**Calibration**”, “**Blank Subtraction**” and “**Sample ID**” inputs. Measurements can be initiated without requiring any additional programming by simply choosing the **Method** and following the on-screen instructions,. Custom methods can be constructed by selecting the **OPTIONS Menu** and modifying existing methods or creating a new method (see **Creating and Editing a Method**).

Unpacking

The L2000DX is shipped in its own carrying case, complete with all the hardware necessary for operation. Upon receiving the L2000DX Analyzer, please verify that all of the items listed below are present and in good working order.

The carrying case for the L2000DX Analyzer should contain the following items:

- L2000DX Electronic PCB/Chloride Analyzer
- Power cube AC-DC transformer
- PC Upload Cable
- Portable electronic balance & 100 gm Calibration weight
- 5 mL pipettor
- Vial rack
- Timer
- Marking pen
- Two empty 20 mL glass vials for RINSE and CALIBRATION solutions
- L2000DX Data Manager Software CD
- Instruction Manual, Certificate of Calibration and MSDS

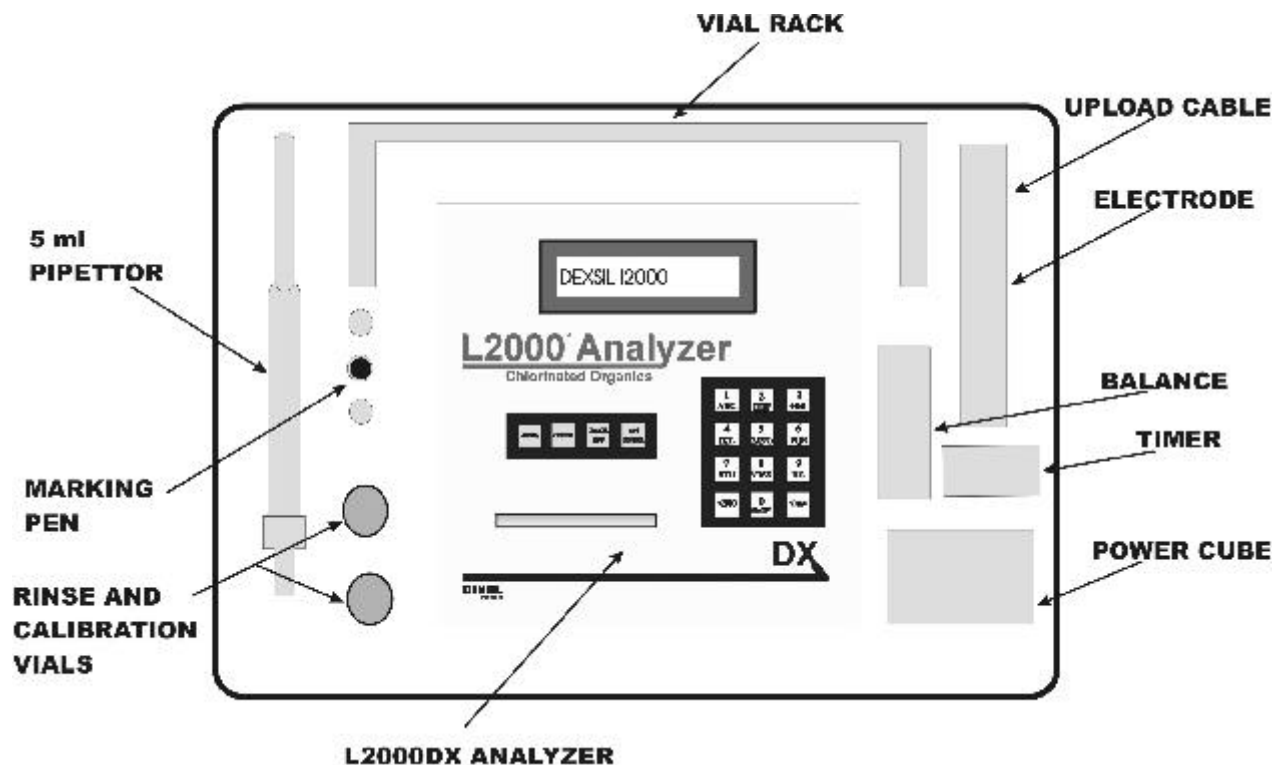

In addition to the aforementioned items in the carrying case, the following should be included in the same outer shipping box:

- Chloride-ion specific electrode¹
- Packet of polishing strips¹
- Test tube rack

To prevent damage to the instrument in the case of a leak, the sample preparation reagents are shipped separately. The exact makeup of the reagent pack will depend on the specific reagent option chosen at the time of ordering. The options available for the L2000DX and the components contained in each are the following:

Option 1: Reagents for 40 Oil Tests

- 1 - 250 mL bottle of EXTRACT solution
- 1 - 250 mL bottle of RINSE solution
- 1 - 250 mL bottle of CALIBRATION solution
- 1 - 60 mL bottle of Electrode Filling Solution
- 1 - tray of 40 empty 20 mL glass vials
- 1 - box of tissue wipes
- 1 - **shelf-pack** containing:

¹ These items are shipped in their original packaging from Orion. Once they have been unpacked, they should be carried in the above-labeled slot in the carrying case.

- 40 - filters
- 40 - pipettes
- 40 - reaction tubes (black dispenser caps)

Reorder Part No: (LP-ORK)

Option 2: Reagents for 20 Soil Tests (Standard Procedure)

- 1 - 250 mL bottle of EXTRACT solution
- 1 - 250 mL bottle of RINSE solution
- 1 - 250 mL bottle of CALIBRATION solution
- 1 - 60 mL bottle of Electrode Filling Solution
- 1 - box of tissue wipes
- 1 - **40-cell box** containing:
 - 20 - empty 20 mL glass vials
 - 20 - bottles containing Soil Extraction Solvent
- 1 - **shelf-pack** containing:
 - 20 - filters
 - 20 - pipettes
 - 20 - reaction tubes (black dispenser caps)
 - 20 - metal scoops for obtaining soil samples
 - 20 - 10 mL plastic syringes
 - 20 - drying columns (foil packed)
 - 20 - empty test tubes with white caps

Reorder Part No: (LP-SRK)

Option 2a: Reagents for 20 Soil Tests (Two-Step Extraction Procedure)

- 1 - 250 mL bottle of EXTRACT solution
- 1 - 250 mL bottle of RINSE solution
- 1 - 250 mL bottle of CALIBRATION solution
- 1 - 60 mL bottle of Electrode Filling Solution
- 1 - box of tissue wipes
- 1 - set of instructions
- 1 - **40-cell box** containing:
 - 20 - empty 20 mL glass vials
 - 20 - 6 mL black-capped water vials
- 1 - **shelf-pack** containing (in a heat sealed foil bag):
 - 20 - empty 25 mL soil tubes
 - 20 - filter funnels
 - 20 - pipettes
 - 20 - reaction tubes with black dispenser caps
 - 20 - break-top vials containing Soil Extraction Solvent
 - 20 - metal scoops for obtaining soil samples
 - 20 - syringe filters (in a heat sealed foil bag)
- 1 - set of instructions

Reorder Part No: (LP-SR2)

Option 3: Reagents for 20 Water Tests

- 1 - 250 mL bottle of EXTRACT solution
- 1 - 250 mL bottle of RINSE solution
- 1 - 250 mL bottle of CALIBRATION solution
- 1 - 60 mL bottle of Electrode Filling Solution
- 1 - box of laboratory wipes
- 1 - **40-cell box** containing:
 - 20 - empty 20 mL glass vials
 - 20 - bottles of Isooctane
- 1 - **shelf-pack** containing:
 - 20 - filters
 - 20 - pipettes
 - 20 - reaction tubes (black dispenser caps)
 - 20 empty test tubes with white caps
- 1 - set of instructions

Reorder Part No: (LP-WTR)

Option 4: Reagents for 20 Wipe Tests

- 1 - 250 mL bottle of EXTRACT solution
- 1 - 250 mL bottle of RINSE solution
- 1 - 250 mL bottle of CALIBRATION solution
- 1 - 60 mL bottle of Electrode Filling Solution
- 1 - box of tissue wipes
- 2 - pair of safety goggles (1 pair/10 tests)
- 2 - pair of neoprene gloves (1 pair/10 tests)
- 1 - **shelf-pack** containing:
 - 20 - filters
 - 20 - pipettes
 - 20 - reaction tubes (black dispenser caps)
 - 20 - hexane ampules
 - 20 - empty test tubes with white dispensing caps
- 1 - **box** containing:
 - 20 - gauze pads in 20 mL glass vials
 - 20 - 10 mL glass bottles containing Extraction Solvent (isooctane)
- 1 - **box** containing:
 - 20 - empty 20 mL glass vials
 - 20 - forceps
- 1 - set of instructions

Reorder Part No: (LP-WIP)

NOTE: DO NOT STORE REAGENTS IN THE INSTRUMENT CARRYING CASE, AS ANY LEAKS WILL DAMAGE THE INSTRUMENT.

Initial Set Up

Once the L2000DX has been unpacked, the components checked and the contents of the reagent pack verified, the L2000DX can be set up for analysis. Locate the vial rack, the two empty 20 mL vials and the bottles of RINSE and CALIBRATION solutions. Remove the caps from both vials and label one 20 mL vial "RINSE" and the other "CAL". Fill each vial approximately ½ full with the appropriate solution and set in vial rack. (NOTE: It is helpful to label the rack with the location of the RINSE and CAL vials.) These solutions will be used for the initial setup and calibration of the electrode. They will also be used periodically to re-calibrate the electrode and check the electrode output. Once set up, the electrode should remain in the RINSE solution when not in use.

Prior to running the Analyzer on battery power, it should be charged overnight using the power cube supplied with the instrument. The Analyzer can be operated from line power while the battery is charging and should be left plugged in whenever AC power is available. Turn on the Analyzer by pressing and holding the <ENTER/ON> key until the printer advances one line and the display reads:

Dexsil L2000DX
Version 1.24

This screen is the **First Screen** in the operating program. The Analyzer is ready to accept instructions.

Restoring the Electrode After Extended Storage

The electrode is shipped empty and should be stored empty whenever it will be left for an extended period of time (see **Electrode Care and Maintenance**). To restore the electrode to operating condition:

1. Remove protective cap from the tip of the electrode.
2. Fill the electrode, up to the filling hole in the side, with the Orion Electrode Filling Solution supplied with each lot of reagents. To fill, place the nozzle of the fill solution bottle into the hole on the side of the plastic body and gently squeeze the fill bottle.
3. Drain the electrode, while holding it upright over the waste beaker, by grasping the body of the electrode firmly in one hand and pushing down on the black cap where the cord enters the electrode. The filling solution will drain out of the bottom of the electrode.
4. Refill the electrode and make sure that the fill solution is making contact between the black cone and the plastic shell at the bottom of the electrode. If it is not making contact at all points, drain the electrode again and refill.
5. Connect the electrode to the BNC connector labeled "ELECTRODE" on the back of the L2000DX Analyzer and check electrode output.
6. To check the electrode, turn the Analyzer on by pressing and holding the <ENTER/ON> key

until the printer advances one line and the display screen activates. Select the **OPTIONS Menu** from the **First Screen** by the pressing <OPTION> key. At the **OPTIONS Menu**, go to “**DIAGNOSTICS**” by pressing the <6> key. This display:

```
DIAGNOSTICS X.X  
XXX.X mV XX.X °C
```

will indicate the current temperature and then continuously update the electrode output in millivolts (mV). Place the electrode in fresh RINSE solution, gently swirl the solution with the electrode and allow to sit. The electrode output should reach 140 mV or greater within 1 minute. If the electrode output does not reach at least 140 mV, empty the RINSE solution and refill with fresh RINSE solution. If this does not improve the electrode output, drain the electrode, refill it with filling solution and check the output again. Once the output is greater than 140 mV, the electrode is functioning correctly and it is safe to proceed with measurements. If the electrode output does not reach 140 mV, see under **Trouble Shooting** for remedies. NOTE: The update rate for the “**D i a g n o s t i c s**” display is 6 seconds, any keys pressed will not register until the end of the current measurement cycle.

Basic Operation of the L2000DX

General Information

The L2000DX meter is equipped with an internal gel cell battery and can be operated with or without the wall adaptor. A fully charged battery should be sufficient to operate for 3 full 8-hour days of sample analyses, printing each data point. To conserve battery power, the printer can be turned off and the stored data printed or uploaded at a later time. To preserve the battery, the unit should be plugged into an AC outlet whenever possible.

The operation of the L2000DX is controlled by a program organized into a series of “screens”. A screen prompts the user for appropriate input or displays output from the processor. There are two screens at the beginning of the program that will be referred to throughout the text. They are, the **First Screen** which appears when the analyzer is turned on and is returned to when turning the meter off manually, and the **SELECT METHOD Screen** which is the next screen in sequence. From the **SELECT METHOD Screen** the desired analytical method is chosen prior to analysis. From this screen the program enters a series of screens that step the user through the analysis of prepared samples. This series includes the calibration steps and blank determination and will loop back for periodic re-calibration as necessary. This section of the program is referred to the **Analysis Loop**. (See below for a block diagram of the program..)

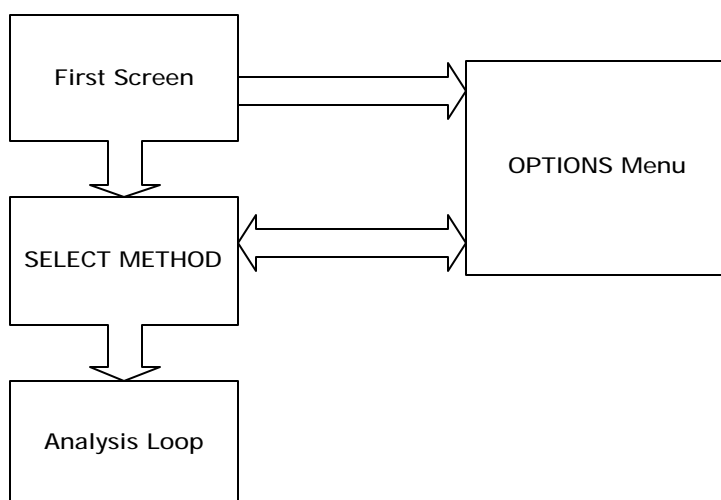

Once in the **Analysis Loop**, the analyzer must be calibrated. The calibration procedure is a single point calibration using a 50 ppm chloride CALIBRATION standard supplied with each batch of reagents. This calibration must be repeated approximately every 20 measurements or one hour, whichever comes first. A timer, a counter, and a thermistor have been built into the instrument to prompt the user for recalibration when necessary. During the calibration procedure, the function of the electrode will also be evaluated. If the electrode potential for the calibration solution is not within the acceptable limits, a warning will be displayed and the program will jump to the diagnostics mode. (See below under **Diagnostics**.)

All other functions of the program are accessed by pressing the <OPTION> key from the **First Screen** or the **SELECT METHOD Screen**. This section of the program is referred to in the manual as the **OPTIONS Menu**. Although only one choice can be displayed at a time, options are organized into a sequence of choices, functioning much the same as a menu typical of most computer programs.

Turning the Analyzer On and Navigating the Operating Program

Pressing and holding the <ENTER/ON> key until the printer advances one line and the display activates will turn the Analyzer on and the program will be in the **First Screen**. In the **First Screen** the display will read:

```
Dexsil L2000DX
Version X.XX
```

indicating the current software version running on the L2000DX. The version number should match the version number indicated on the cover of this manual.

From the **First Screen** pressing the <ENTER/ON> key will move the program to the **SELECT METHOD Screen**. In the **SELECT METHOD Screen**:

```
SELECT METHOD
method id
```

pressing the <<NO> and <YES>> keys will scroll through the stored methods. When the desired method is displayed, pressing the <ENTER/ON> key will select it. The program will then enter the **Analysis Loop** and the program will begin prompting one through the operations necessary to begin the analysis of samples using the chosen method.

Calibration

The first step required before any measurements can be made is to calibrate the instrument. The L2000DX operating program will jump to the **CALIBRATION** screen when a new method is selected, when the temperature has changed by more than 5 EC, or when the recalibration timer is triggered. The display will read:

```
CALIBRATION FOR
method name
```

indicating the method that is currently selected. Press the <ENTER/ON> or <YES>> keys and the display will indicate that the electrode should be placed in clean fresh **CALIBRATION** solution:

```
IS CALIBRATION
SOLUTION READY
```

Remove the electrode from the RINSE solution, gently wipe the body of the electrode with a clean wipe and insert the tip into the CALIBRATION solution. NOTE: DO NOT WIPE THE TIP OF THE ELECTRODE AS THIS MAY DAMAGE IT. Swirl the electrode gently a few times and press the <ENTER/ON> or <YES>> key. Allow the electrode to remain in the calibration solution, the meter will briefly display the message:

MEASUREMENT IN
PROGRESS

Provided the electrode output is within the acceptable range and the ambient temperature is also within the acceptable range, the calibration procedure is complete when the program display briefly:

CAL TEMP = XX °C
mV = XX

The calibration results will also be sent to the printer, if the printer has been turned on.

Cal ibration: *hh:mm mm/dd/yyyy*
Version: *XXXX*
Method: *METHOD NAME*
mV = *xx.x* Temp. = *xx.x* °C
A = *xxx.x* B = *xx.xxx*
Offset = *x.x*

The program function will then move to the next step in the chosen method. If the temperature is outside the acceptable range the following error message will be displayed:

Temperature
Error *xx.x* °C

A temperature error indicates that the ambient conditions are not suitable for measurement. Save all extracts and move to a location where the temperature is within the acceptable range.

If the electrode output is outside the acceptable range, an error will be displayed:

CAL ERROR
mV = XX

Pressing the <ENTER/ON> key will move the program back to the beginning of the **Analysis Loop**. (See “CAL ERROR” in **Error Messages** under **Trouble Shooting**)

Blank Determination

All of the pre-programmed methods have the option of subtracting a reagent blank built into the method. If blank subtraction has been enabled in the chosen method, this option will be presented after each calibration. The option will be presented as:

```
USE BLANK
YES/NO
```

If NO is chosen, the program moves on to the next step in the method as described below in **Analysis**. If YES is chosen, the option will be presented:

```
USE PREVIOUS
BLANK YES/NO
```

If YES is chosen, an opportunity will be presented to change the stored blank or to enter a fixed value at:

```
USING BLANK OF
0.00
```

This number, in ppm chloride, can be edited or accepted, as is, by pressing the <ENTER/ON> key. The program then continues to the next step as described below under **Analysis**.

If NO is chosen, the screen will prompt for the blank solution:

```
PUT PROBE INTO
BLANK <ENTER>
```

The blank solution must be prepared as a sample would be, using all of the sample preparation steps and reagents but without an actual sample.² After reaction the blank must be allowed to reach room temperature as described below. Insert the electrode into the solution, swirl gently for a few seconds and allow to sit. With the electrode in the solution, press the <ENTER/ON> or <YES>> key. After the measurement has been made, the blank result will be displayed as:

```
BLANK READING
01.2
```

After pressing the <ENTER/ON> key, the program will continue to the next step in the analysis as described below. A measured blank cannot be edited. Only stored blank values can be edited.

² When preparing a blank using the Standard Soil Extraction Solvent, DO NOT add any of the water from the bottom of the solvent vial.

Analysis

Prepare samples for analysis as described under **Sample Preparation**. Once the samples have been prepared, choose the appropriate analysis method and calibrate the meter. The program will display instructions as determined by the chosen method.

1. Make sure that the method has been selected, the instrument has been recently calibrated (including any blank determinations) and that the analysis solutions have been allowed to temperature equilibrate for at least 5 minutes. The display should read:

ANALYZE SAMPLE
method name

Press the <ENTER/ON> key to continue to the screen:

SAMPLE ID (save)
sample id

If the sample ID is correct, proceed to the next step. Otherwise change the ID as described under **Entering Data**. The indication “save” will appear in this screen if the option to save data points as they are taken has been selected (See **Data Management**)

2. Remove the electrode from the rinse solution and wipe the body carefully with a tissue. NOTE: DO NOT WIPE THE TIP OF THE ELECTRODE AS THIS MAY DAMAGE IT. Place the electrode in the vial to be analyzed and swirl it gently for several seconds.
3. Press the <ENTER/ON> key. The L2000DX will take a series of readings. Once the readings have converged on a constant value, the result will be displayed along with crucial method information. A beeper will sound to indicate that the new value is ready.
4. To analyze additional samples, press the <ENTER/ON> key. The program will check the ambient temperature and, if it is still within the allowable range, the program will cycle back to begin the next analysis. Proceed as in step 1 above to make the next measurement.
5. Samples may be saved for analysis at a later time, but the vials should be tightly capped. Once they have been read, samples should be discarded. Do **not** re-analyze samples.
6. Pipettes and oil should be disposed of as PCB/Organo-chlorine waste. Analysis solution can be disposed of as ordinary aqueous waste containing nickel.

Entering Data

All user input to the L2000DX Analyzer is through the 16 key keypad on the front panel. There are 12 alpha-numeric keys and 4 function keys. Audible feedback is provided, on all keys, to indicate that a key press has been registered by the processor. Data is entered using the alpha-numeric keys. These keys are active only when an input is required and will be acted on only when they are appropriate for the active screen.

When numeric input is required, only the numbers indicated on the keys will be registered. To change an entered number, use the arrow keys to move the cursor to the desired location and press the correct number key. To input letters in a text string, such as in a method name or sample ID, both an alpha-numeric key and the ALPHA key must be pressed. When an alpha-numeric key is pressed, the number associated with that key will be displayed first. The ALPHA key is then pressed once, twice, or three times to change the character to the desired letter. Continued ALPHA key presses will “scroll” the characters through the letters and the number shown on the face of the key. For example: Pressing the <7> key will first cause the “7” to be displayed. The cursor will move to the next space and, if the ALPHA key is pressed next, the “7” changes first to an “S”, then a “T”, followed by a “U”. (Pressing the <ALPHA> key again will cycle the character back to the “7”.) Once the desired character is displayed, pressing an alpha-numeric key will enter the next character, above the cursor.

Having a sample ID that includes a number automatically incrementing with each successive sample, will make assigning a unique sample ID much easier. This is accomplished by using “wildcards” in the sample ID. There are two “wildcard” characters that can be used. These are the “*” and the “?”. They function much the same as their DOS equivalents. Entering an “*” in a sample ID will add an automatically sequencing number to the sample ID. The number begins at 00001 and increments up to 99999. (If less than 5 spaces are left in the sample ID then the number is limited to the number of digits left.) The “?” has the same function as the “*” but the appended number will only have the number of digits as question marks entered. NOTE: Editing a sample ID with a “wildcard” will freeze the number at the current value and eliminate the wildcard function.

Special Keys

The <NO and YES> keys function as either a yes/no response or as arrow keys to move the cursor through a text entry.

The four special function keys, ALPHA, OPTION, BACK/OFF and ENTER/ON are used to direct the operation of the program. The ALPHA key is used to input letters in a text string. The OPTION key, from the first or second screen, will transfer program operation to the **OPTIONS Menu**. From the **RESULT Screen** in the **Analysis Loop**, the OPTION key is used to view the chosen parameters of the currently active “Method”. The BACK/OFF key is used to exit from any section of the program, back through successive screens to the **First Screen** and, ultimately, to turn the meter off. The ENTER/ON key will turn the instrument on and is used to enter any options chosen or to step forward in the program.

Electrode Check

The electrode is the most important component in the system. It is, therefore, important that the electrode be properly maintained and the initial setup will determine how well the electrode is functioning. Before turning the L2000DX analyzer on, insure that the electrode is properly connected to the back of the unit. Check the fill level in the electrode and, if necessary, refill the electrode with the Orion filling solution supplied with each lot of reagents. To fill the electrode, insert the tip of the filling spout of the filling solution bottle into the hole on the side of the electrode. Slowly squeeze the solution into the electrode body until it reaches the level of the hole.

Once the electrode has been filled, check the electrode output by going to “**Diagnostics**” from the **OPTIONS Menu**. Rinse and refill the RINSE vial with fresh rinse solution and swirl the electrode in the solution gently for a few seconds. Allowing the electrode to sit in the rinse solution, verify that the mV reading is greater than 140 mV. If the output does not reach at least 140 mV within a minute, refill the RINSE vial with fresh solution and recheck the output. If this does not improve the output, refill the electrode with fresh fill solution. (See **Electrode Care and Maintenance**).

Sample Preparation

Oil Samples

Before a transformer oil sample can be analyzed with the L2000DX, the PCB/Chlorinated Organics must be chemically converted to chloride.

1. Remove the cap from a black-capped tube and add oil up to the 5 mL line using a polyethylene pipettor (See Figure 2). Replace the cap tightly on the tube.

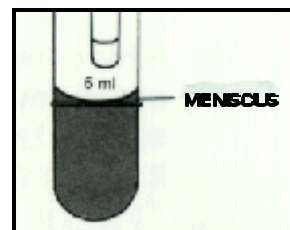

Figure 2

2. Break the bottom (colorless) ampule in the tube. Shake the tube well for 10 seconds.

3. Break the top (gray) ampule in the tube. Shake the tube vigorously for 10 seconds. Allow the reaction to proceed for additional 50 seconds (total of one minute), while shaking intermittently several times.

4. Using the 5 mL pipette, add five milliliters of extract solution to the back-capped tube. Tighten the cap securely and shake vigorously until the foam and dark color disappear. Vent the tube by partially unscrewing the black cap while holding the tube upright. Squeeze the test tube slightly while re-tightening the cap, and shake the tube vigorously for 20 seconds more. Vent again, tighten cap and stand the tube upside-down on the flat top of the cap and allow to settle for two minutes.

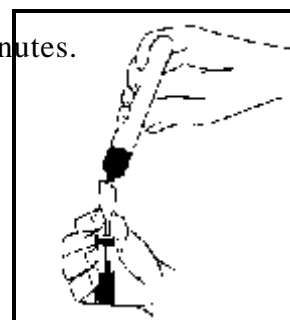

Figure 3

5. Place a polyethylene filter funnel in one of the 20 mL glass vials marked with the sample number. Position the black-capped test tube directly over the top of the funnel and open the dispenser nozzle (See Figure 3). Dispense the solution by carefully squeezing the sides of the tube. Stop as soon as the first drop of oil appears. Allow the solution to pass through the funnel, but remove the funnel before any oil can get through. Allow the solution to cool for five minutes. The sample is now ready for analysis.

Soil Samples

To analyze a soil sample for PCB/Chlorinated Organics, the analyte must first be extracted from the sample. There are two solvent extraction systems available. Depending on the specific application, either the standard extraction solvent or the two-step procedure will be most appropriate. Both systems provide good, reproducible recoveries on dry sandy loam type soils. The standard procedure is somewhat faster and has fewer steps, but should not be used on wet or heavy clay soils. Regardless of the solvent system used, it is important that split samples be periodically analyzed by a reputable laboratory, not only to identify/confirm the Aroclor present, but also to confirm the extraction efficiency of the L2000DX solvent system. Contact Dexsil before trying to analyze other types of materials. NOTE: The quality of the final result is directly determined by sampling technique. It is, therefore, important to use proper protocols for sample collection and homogenization.

Standard Procedure for Soil Analysis

1. Using the metal spatula and the portable electronic balance supplied with the kit, weigh out ten grams of the soil into the empty, white-capped test tube. NOTE: Be careful not to get any foreign material into the weighed sample, i.e., absorbent material, large rocks, etc. The empty tube can be tared by placing it on the balance and pressing the <ON/OFF/ZERO> key.

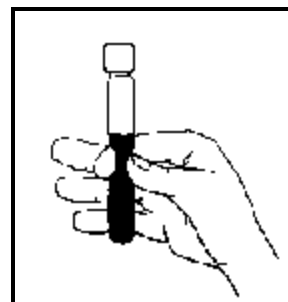

Figure 4

2. Remove the black cap from the glass vial containing the extraction solvent and pour the entire contents of the vial into the tube containing the soil. Replace the white cap on the plastic test tube tightly and shake the tube vigorously for one minute. Break up any lumps of soil by squeezing the sides of the test tube during the shaking process. (See Figure 4) Allow the tube to settle upright for two minutes.
3. Remove the drying column from its foil pouch by poking the pointed end of the column through the foil and remove the red end-cap. Pull the plunger completely out of the 10cc syringe. Attach the end of the blue drying column to the tip of the syringe by sliding it over the collar on the tip of the syringe. This is a tight fit and the drying column may have to be carefully worked onto the syringe. Make sure that it is seated tightly.
4. Remove the black dispensing cap from the plastic test tube that contains two glass ampules. Slide the syringe-drying column assembly part of the way into the test tube which contains the two ampules. Stand the whole assembly upright. Using the polyethylene pipettor, remove the extraction solvent from on top of the soil and dispense it into the top of the open syringe barrel. You will need to recover enough extraction solvent to fill the syringe barrel to the 7 mL level. Try not to remove any soil with the solvent as this may clog up the drying column. After 7 mL of solvent has been dispensed into the syringe, replace the plunger into the back of the syringe and apply pressure so that the solvent is forced through the drying column at the rate of 2 or 3 drops per second. (NOTE: Do not force the solvent through the drying column too fast.) When the dried solvent fills the test tube to the 5 mL line, pull back on the plunger to stop the flow of solvent. Remove the syringe-drying column assembly from the test tube, and screw the black dispensing cap tightly onto the test tube.
5. Break the bottom (colorless) ampule in the test tube by squeezing the sides of the tube and shake the mixture well for 10 seconds. Break the top (gray) ampule in the test tube and shake the tube vigorously for 10 seconds. Allow the reaction to proceed for additional 50 seconds (total of one minute), while shaking intermittently several times.
6. Using the 5 mL pipettor, add five milliliters of extract solution to the back-capped tube. Tighten the cap securely and shake vigorously until the foam and dark color disappear. Vent the tube by partially unscrewing the black cap while holding the tube upright. Squeeze the test tube slightly while re-tightening the cap, and shake the tube vigorously for 20 seconds more. Vent again, tighten cap and stand the tube upside-down on the flat top of the cap and allow to settle for two minutes.

7. Place a polyethylene filter funnel in one of the 20 mL glass vials marked with the sample number. Position the black-capped test tube directly over the top of the funnel and open the dispenser nozzle. (See Figure 3) Dispense the solution by carefully squeezing the sides of the tube. Stop as soon as the first drop of the organic solvent appears. Allow the solution to pass through the funnel, but remove the funnel before any oil can get through. Allow the solution to cool for five minutes. The sample is now ready for analysis.

Two-Step Procedure for Soil Analysis:

1. Using the metal spatula and the portable electronic balance supplied with the kit, weigh out ten grams of the soil into the empty, white-capped test tube. NOTE: Be careful not to get any foreign material into the weighed sample, i.e. absorbent material, large rocks, etc. The empty tube can be tared by placing it on the balance and pressing the <ON/OFF/ZERO> key.
2. Add the contents of one break-top glass solvent vial to the test tube of soil sample. Replace the cap tightly on the tube and shake contents for 3 minutes making sure the entire soil sample is thoroughly wetted.
3. Add the colored water component contained in the 6 ml black-capped vial to the test tube. Recap tightly and shake for an additional 2 minutes.
4. Allow the mixture to separate for 2 minutes.
5. Remove the plunger from a syringe/filter unit in the foil package and remove the black-dispensing cap from the reaction test tube and stand it in the rack.
6. Remove the top layer from the soil test tube (solvent layer) using the polypropylene pipette provided and while holding the syringe/filter over the reaction tube, add 7 ml to the syringe/filter.
7. Add solvent from the syringe/filter up to the 5 ml line of the black-capped test tube. Replace the cap tightly on the tube.
8. Break the bottom (colorless) ampule in the black-capped test tube by squeezing the sides of the tube and shake the mixture for 10 seconds.
9. Break the top (gray) ampule in the test tube and shake the tube vigorously for 10 seconds. Allow the reaction to proceed for an additional 40 seconds (total of one minute), while shaking intermittently several times.
10. Using the 5 milliliter pipettor from the basic L2000 system, add 5 ml of the L2000 Extraction solution to the black-capped tube. Tighten the cap securely and shake the tube vigorously until the foam and dark color disappears. Vent the tube by partially unscrewing the cap while holding the tube upright. Squeeze the test tube slightly while retightening the cap and shake a second time. Vent again, retighten cap and stand the tube upside-down on the flat top of the cap and allow to settle for two minutes.

11. Place a filter funnel in one of the 20 ml glass vials marked with a sample number. Position the black-capped test tube directly over the top of the funnel and open the dispenser nozzle. Dispense the solution by carefully squeezing the sides of the tube. Allow the solution to pass through the funnel, but remove the funnel before any oil can get through. Allow the filtered solution to cool for five minutes. The sample is now ready for analysis with the L2000 Analyzer.

Water Samples

High Range (5-2000 ppm)

1. Fill sample tube with 10 grams of water sample.
2. Add 10 mL of isooctane extraction solvent and shake vigorously for 30 seconds.
3. Allow to separate into two phases for a minimum of 2 minutes. (If an emulsion forms, add sodium sulfate*, shake and allow to separate again). Using the disposable plastic pipette remove 5 mL of the top solvent layer and add to the black capped reaction tube. (*available from major chemical suppliers).
4. Proceed with test as for an oil sample and quantify using the appropriate LX2000DX method.

Low Range (20 ppb - 5 ppm)

1. Collect sample in 1 quart narrow mouth glass bottle with zero head space. Cap tightly and store on ice until analysis.
2. When ready to analyze the sample, invert sample container gently once or twice and, using a plastic pipette, remove 35 mL of water from the sample jar by weighing 35 grams of water into a tared waste container and discard. Then add 10 mL of isooctane to sample container and shake vigorously for 2 minutes.
3. Add sufficient chlorine free distilled water to bring the water level up into the neck of the sample bottle (the solvent level should be just shy of the top of the neck) and allow to set for 3 minutes.
4. Withdraw 5 mL of the upper solvent layer (**Do Not Remove Any Water With the Solvent**), add to the black capped reaction tube and cap tube tightly.
5. Proceed with the analysis as for an oil sample and quantify using the appropriate L2000DX method.

Wipe Samples

1. Locate the sealed glass vials containing chromatographic grade hexane and carefully break off the tip. Pour the entire contents into the vial containing the gauze pad. Grasp the soaked gauze pad with the disposable forceps and using an approved technique, wipe an area of 1000 cm². 1000

cm² is equivalent to a square measuring 31.6 cm or 12.5 inches on each side. It is equal to 1.08 ft². Allow the hexane to evaporate from the wiping material (approximately 1 minute).

2. Being careful not to contaminate the wipe, place it as loosely as possible into the tube with the white dispenser cap. Pour the extraction fluid, (10 mL of isooctane), into the white-capped tube. Tighten the cap and solvate the gauze thoroughly for 30 seconds. Squeeze the tube to make sure that the isooctane completely washes the gauze. This solvent now contains all the PCBs that were removed during the wiping procedure.
3. Remove the black dispenser cap from one of the reaction tubes. Open the spout on the white dispenser-capped test tube and dispense the isooctane extract into the black-capped tube up to the 5 mL line. Replace the cap tightly on the tube.
4. Break the bottom (colorless) ampule in the tube. Shake the tube well for 10 seconds.
5. Break the top (gray) ampule in the tube. Shake the tube vigorously for 10 seconds. Allow the reaction to proceed for additional 50 seconds (total of one minute), while shaking intermittently several times.
6. Using the 5 mL pipette, add five milliliters of extract solution to the back-capped tube. Tighten the cap securely and shake vigorously until the foam and dark color disappear. Vent the tube by partially unscrewing the black cap while holding the tube upright. Squeeze the test tube slightly while re-tightening the cap, and shake the tube vigorously for 20 seconds more. Vent again, tighten cap and stand the tube upside-down on the flat top of the cap and allow to settle for two minutes.
7. Place a polyethylene filter funnel in one of the 20 mL glass vials marked with the sample number. Position the black-capped test tube directly over the top of the funnel and open the dispenser nozzle (See Figure 3). Dispense the solution by carefully squeezing the sides of the tube. Stop as soon as the first drop of oil appears. Allow the solution to pass through the funnel, but remove the funnel before any oil can get through. Allow the solution to cool for five minutes. The sample is now ready for analysis.

The OPTIONS Menu

Except for the **Analysis Loop**, all program functions of the L2000DX are accessed through the **OPTIONS Menu**. The options available are:

- 1) METHOD - CREATE/EDIT
- 2) HEADER INFORMATION
- 3) DATA MANAGEMENT
- 4) PRINTER OPTIONS
- 5) TIME AND DATE
- 6) DIAGNOSTICS
- 7) PC UPLOAD
- 8) SET TEMP

The **OPTIONS Menu** is entered by pressing the <OPTION> key at the **First Screen** or the **SELECT METHOD Screen**. Once in the **OPTIONS Menu**, each option will be displayed for 3 seconds and they will continually loop for 3 minutes or until an option is chosen. An option is chosen by pressing the appropriate number for the desired option.

I) Creating and Editing a Method

The key to the utility of the L2000DX analyzer is the versatility of the methods that can be developed for the instrument. A “method” is the complete set of parameters that are necessary to convert a chloride reading into an accurate quantification of the targeted analyte. Preprogrammed in the meter are a number of methods for the analysis of many common environmental contaminants. These methods can be modified and custom methods can be built by setting any of the conversion parameters used to convert the chloride reading into an equivalent analyte concentration.

Each method requires 8 parameters to be set. These parameters are determined by the composition of the sample and the chemistry of the sample preparation and/or extraction procedures used to introduce the sample into the system. They can be either calculated from known parameters or determined empirically from preliminary experiments. The parameters common to all methods and their allowable ranges are tabulated below.

Parameter	Range of Values
Blank Subtraction	yes/no
Chlorine Content	10 - 99.9
Sample Size Correction	0.01 - 99.9
Extraction Efficiency Correction	0.01 - 99.9
Matrix	Oil, Soil, Water, Wipe
Units to be Displayed	ppm, mg/kg/ ppb, ug/sdm
Analyte Label	16 character alpha-numeric
Method Name	16 character alpha-numeric

To create a new method or edit an existing method choose 1) **AMETHOD CREATE/EDIT** from the **OPTIONS Menu**. Then choose either 1) **AEDIT METHOD@** to edit an existing method or 2) **ACREATE NEW@** to create an entirely new method. Choosing 2) **ACREATE NEW@** will begin the parameter selection for the new method directly. If 1) **AEDIT METHOD@** is chosen, the next screen will be:

```
CHOOSE METHOD :x
method names
```

to choose the method to edit. The existing method names can be viewed by pressing the <<NO> key to scroll backward or <YES>> key to scroll forward. Once the desired method is displayed pressing the <ENTER/ON> key will select the method and the choice will be given to either:

```
1) MODIFY METHOD
2) DELETE METHOD
```

Choosing 2) **ADELETE METHOD@** will delete the chosen method. This is the only way to delete unwanted methods. (NOTE: Preprogramed methods cannot be deleted. Only user created methods can be deleted.) Choosing 1) **AMODIFY METHOD@** will begin the method parameter editing. After this screen, whether editing or creating a method, the steps are the same.

Blank Subtraction

The first parameter that will be displayed will be:

```
BLANK SUBTRACT
YES OR NO
```

Enabling blank subtraction allows for the subtraction of a reagent blank, if any, from the raw chloride measurement before the final result is displayed. When blank subtract is on, the analyst will be prompted to either measure a blank, use a previous blank or input a blank value to be used. During the analysis of unknowns, if a blank is subtracted, the results will be displayed with a “B” in the upper right corner of the display.

Chlorine Content

The next parameter that can be input is the chlorine content of the target analyte.

 % CHLORINE XX.X
 99.9%

Input as a percentage, this parameter is used to convert the total chloride reading into an equivalent analyte concentration prior to the display of the result.

Size Correction

The size correction is used to adjust the results for the sample size used for a particular analysis. The assumed sample size is 5 grams of a liquid sample, 10 grams for a soil sample and 1000 cm² for wipe samples. The correction would be calculated from the ratio of the expected sample size to the actual sample size. For example, if a 5 gram sample is used for soil analysis, the correction would be 10/5 or 2. NOTE: In the analysis of transformer oil, the sample is typically taken volumetrically, therefore, a correction for the density of the oil is incorporated into all pre-programmed Oil Methods. The density of a typical dielectric fluid used in transformers, Diala-A, is 0.8833 g/cc. The size multiplier, built into each Oil Method, is then 1/0.8833 = 1.13. This allows the results to be displayed as ppm or mg/kg. The size correction screen is:

 SIZE MULTIPLIER
 1.13

Extraction Efficiency Correction

Because there are one or more extractions involved in the preparation of samples for measurement, a correction for extraction efficiency has been provided for in the method parameters in the screen:

 EXTRACTION MULT
 1.11

The correction is entered as a multiplier applied to the final result. For example the recovery of chloride ions from the organic phase in the final extraction of oil samples is 90%. For oil samples, this is the only extraction step, therefore, the correction multiplier would then be 1/0.90 or 1.11. The typical extraction efficiency for the recovery of organics from soil samples is 80%. Combined with a chloride recovery of 90% the overall extraction correction is (1/(0.80 x 0.90)) or 1.39.

Matrix

The matrix label for sample type appears in the header information and indicates what type of sample was analyzed. The available labels are:

1) OIL 2) SOIL
3) WATER 4) WIPE

To choose the matrix label enter the number of the matrix option and press the <ENTER/ON> key. NOTE: This is a label only. Choosing a matrix does not set any of the numeric conversion factors. They must be set separately.

Units

The units variable in a particular method development is simply the text that appears associated with the displayed, printed or stored result. To choose a label, press the number for the desired units. The available labels are:

1) PPM 2) MG/KG
3) PPB 4) ug/sdm

Any of the units can be combined with any of the matrices chosen, however, ug/sdm is only meaningful for wipe samples. The units “ug/sdm” is shorthand notation for **micrograms per square decimeter** which is equivalent to micrograms per 100 square centimeters, i.e., $\text{ug/sdm} = \text{ug}/100\text{scm}$.

Analyte Label

The analyte label is a 16 character label that will appear on the display indicating the analyte equivalent concentration, assuming that all organic chlorine detected in the sample were that analyte. The entry screen appears as:

ANALYTE LABEL
analyte label

This label can be left blank, however, something should be entered as this is the only way to identify the expected analyte when the final analytical result is displayed.

Method Name

After all of the method variables have been selected, the user will be prompted for the name under which the method will be stored in memory:

METHOD NAME
method name

There must be a unique name associated with each method. A method name consisting of all blanks is not allowed for this option. If an existing method name is entered, the prompt:

EXISTING METHOD
OVERWRITE IT?

will appear. Choosing YES will cause the new method to over write the existing one. (NOTE: Pre-programmed methods cannot be over-written. If they are modified, they must be stored as a new method.) Choosing NO will loop the program back to the **METHOD NAME** screen for a new file name. Once a valid method name has been selected, program operation will return to the **OPTIONS Menu**.

2) Header Information

Associated with each block of data are descriptors that will identify all of the important information needed to use the collected data at a later date. Along with the method information, date and time, etc., are header fields available for user selected information. Each of these fields is 16 characters long and the information is entered from the key pad as described under **Entering Data**. The available fields are:

Operator ID
Customer ID
Job ID
Location ID
Comments

If any of these parameters are changed a new header will be stored in memory, to be linked with the data, as well as printed on the printout, if the printer is enabled. The individual fields are edited through each of the individual screens. Text is entered as described under **Data Entry**.

When printed, the header information will appear as follows:

Time (hh:mm)	Date (mm/dd/yyyy)	Operator ID
Customer ID		Job ID
Location		Comments
Method Name		Matrix
BLANK SUBTRACT: (yes/no, If yes: value)		Analyte Label
SAMPLE ID	CHLORIDE READING	ANALYTE CONCENTRATION

Pressing the <2> key, while in the **OPTION Menu**, will begin the editing of header information at the screen:

HEADER SETUP
<BACK> TO RETURN

Pressing the <ENTER/ON> key will continue to the next screen:

```
OPERATOR ID
XXXXXXXXXXXXXXXXXX
```

After editing the text, pressing the <ENTER/ON> key will allow editing of the next header field:

```
CUSTOMER ID
XXXXXXXXXXXXXXXXXX
```

After editing the text, pressing the <ENTER/ON> key will allow editing of the next header field:

```
JOB ID
XXXXXXXXXXXXXXXXXX
```

After editing the text, pressing the <ENTER/ON> key will allow editing of the next header field:

```
LOCATION ID
XXXXXXXXXXXXXXXXXX
```

After editing the text, pressing the <ENTER/ON> key will allow editing of the next header field:

```
COMMENTS
XXXXXXXXXXXXXXXXXX
```

After editing **COMMENTS**, pressing the <ENTER/ON> key will loop the program back to the first **HEADER SETUP** screen. Pressing the <BACK/OFF> key will exit to the **OPTION Menu** or pressing the <ENTER/ON> key will begin the editing process again.

3) DATA MANAGEMENT

A number of data management options are available to the user. They can be selected from the **DATA MANAGEMENT Menu**. Data management options are selected independent of the method chosen and remain in effect until changed by selecting a new option. Enter the **DATA MANAGEMENT Menu** by pressing the <3> key from the **OPTION Menu**. The first option is:

```
STORE EACH
POINT (Y/N)?
```

Activating this option by pressing the <YES>> key will cause each data point to be stored in memory as it is taken. Data points are stored along with all of the method and header information associated with them. The default for data storage is to store each data point. All data points will be stored automatically unless this option is changed. Pressing the <<NO> key will deactivate this option and no further data will be stored unless this option is activated again.

Once the data storage option has been chosen the next screen is:

CLEAR DATA
MEMORY (Y/N)?

This option should be used periodically to clear out old or unwanted data. Choosing this option erases all stored data and header information and reformats the data storage space. The current header information and the current method are not altered. After choosing this option, confirmation will be required before the data will actually be erased:

ALL DATA WILL BE
LOST. PROCEED?

Pressing the <YES>> or <<NO> key will complete this option as desired and exit back to the **OPTION Menu**.

4) PRINTER OPTIONS

The default option for the printer is to print all data points as they are collected. Anytime the header information is edited, a new header is printed. Anytime an external printer is connected to the printer port on the back of the unit, all printouts will be directed to the external printer.

The first option under **4) PRINTER OPTIONS** is:

PRINT POINTS
WHEN TAKEN (Y/N)?

Pressing the <YES>> key will cause each data point to be printed as it is taken. (This option refers only to the printing of data in the **Analysis Loop**. Printing stored data points is the next option.) This option can be turned off to save battery power in the field. It will also be turned off automatically if a low power condition exists. Turning off the print option by pressing the <<NO> key will result in no data printout when the data is taken in the **Analysis Loop**. To obtain a hard copy of the data, the data can be printed at a later time.

To print data after it has been stored, press the <YES>> key from the screen:

PRINT LAST XXXX
POINTS

Choosing this option will cause the last xxxx data points to be printed on either the internal or an external printer. The default is all of the stored data. This number can be edited using the numeric key pad.

To print the current header information, press the <YES>> key from the screen:

```
PRINT HEADER NOW
(Y/N)?
```

This option will print all of the header information on the current printer.

The last print option is to print out a hard copy of the method parameters. At the screen:

```
PRINT METHOD NOW
(Y/N)
```

Press the <YES>> key to print the method.

5) DATE AND TIME

To change the date and/or the time, choose this option and enter the correct information in the indicated fields. The first option to change is:

```
TIME XX:XX
hh:mm <ENTER>
```

Enter the time using the 24 hour clock: hours then minutes. The last entry will cause the current time to be briefly displayed and then the screen:

```
DATE mm/dd/yyyy
mm/dd/yyyy <ENTER>
```

Enter the date as a 2-digit month and day followed by 4-digit year.

6) DIAGNOSTICS

This option should be used to periodically check the output of the electrode, such as at the beginning of each day or if the electrode has been stored for an extended period of time. Or, if an electrode error occurs, this option will allow the user to verify the fault and take corrective action. Once this option has been chosen, the L2000DX will begin measuring the mV output of the electrode and display the results along with the ambient temperature.

```
DIAGNOSTICS x.xx
xx.x mV xx °C
```

7) UP LOAD

Chose this option to upload stored data to a PC. The L2000DX Data Manager must be loaded an running on the target PC. (See **L2000DX Data Manager**.)

To upload data, first connect the L2000DX Analyzer to the PC using the upload cable provided. Once connected, select the **7) PC UPLOAD** option by pressing the <7> key from the **OPTION Menu**. The display will change to:

```
BEGIN UPLOAD
<BACK> TO STOP
```

Then, from the PC, choose BEGIN UPLOAD to begin the upload.

8) SET TEMP

This option allows for the field adjustment of the internal thermistor. When adjusting the L2000DX thermistor, the resulting temperature measurements are only as accurate as the thermometer used for adjustment.

To adjust the internal thermistor, choose **8) SET TEMP** by pressing the <8> key from the **OPTIONS Menu**. The L2000DX will check the current temperature and display the raw result on the screen:

```
INPUT TEMP IN °C
XX.X °C (RAW)
```

enter the current temperature followed by pressing the <ENTER/ON> key. The adjusted temperature will be displayed with the message:

```
NEW TEMP TO USE
XX.X °C OK(Y/N)?
```

NOTE: An adjustment of $\pm 5^{\circ}\text{C}$ max. is allowed. If the input temperature differs by more than this, the temperature will be fixed at the max/min allowed.

L2000DX Data Manager

Introduction

The L2000DX Data Manager is a PC based data base program specifically designed for data from the L2000DX Analyzer. It provides four basic capabilities: uploading stored data, report generation, data export functions and basic data base functions for tracking data from one or more L2000DX Analyzers.

Installation

To install the Data Manager: Insert program CD into CD drive and run setup.exe. The install program will provide guidance for all installation steps.

Uploading data

Each time you upload data from a particular L2000DX unit, the software reads from the unit the date it was last cleared and stores this date for future reference. It also stores the number of the last record uploaded. The next time you upload data from the same unit, the software compares the date it reads from the unit with the stored date. If they are the same, it continues uploading data from the last uploaded record, eliminating any duplication in your data set. If the dates are different, the software assumes you have cleared the unit since your last upload and begins uploading data with the first record in the unit.

Note that the software keeps track of multiple L2000DX units by reading from each unit its unique, factory-supplied serial number.

To upload data from an L2000DX analyzer, connect the analyzer to the PC using the supplied cable then select **7) PC UPLOAD** on the L2000DX unit. Once the unit is connected and ready to upload choose **Upload** from the **Communicate** menu on the PC. Choosing it opens the **L2000DX Upload** box. Once this box is open click **OK**. The program will contact the L2000DX analyzer and begin uploading stored data.

If you want to cancel the process, click on the **X** in the upper right corner of the box, then click **Abort Transfer** in the resulting **Communication Status** message box.

Selecting Data

Choosing **Selection** at the menu bar causes the **Define Sample Selections** dialog box to appear. Here you can choose to display only some of the available data records by using combinations of various filters.

Note: These filters will affect the display, printing and export of data.

Selection Filter - This heading (left side of the dialog box) contains four selections: **Header**, **Customer**, **Job** and **Location**. Check the checkbox for the filter(s) you want to use. You cannot

combine **Header** with any of the other three filters, however the other three may be used in any combination. When you select one of the filters, a drop-down menu appears displaying the values available in the active data set.

Header Range Filter- This area lets you choose a range of consecutive Header numbers. The Starting and Ending must be different, and the Ending number must be greater than the Starting number.

Sample Range Filter- This area lets you choose a range of consecutive Ref #s. The Starting and Ending may be the same, but the Ending number must be greater than the Starting number.

As you make various filter selections, the data in the L2000DX window will change to reflect your choices, even while the Define Sample Selections dialog box is open.

The L2000DX Data Manager combines filters so that the data displayed, printed or exported satisfies all the filters. For example, if you select a **Customer** and a **Job** filter, you will see only data records with the required Customer number and the required Job number, not data with either the Customer number or the Job number.

As soon as you select any filter, a **Clear All** button appears in the dialog box to allow you to quickly clear all filter selections. A **Clear All Filters** button will also appear on the L2000DX Data Manager window so you can clear filters later without returning to the **Define Sample Selections** dialog box.

Generating a Report

Choosing **Print Report** at the **File** menu causes the **Report Page Format** dialog box to appear. This box allows you to specify a title for your report.

In the edit field, type a title of up to 70 characters to be centered in the header of the report form.

Click the **Print Preview** button to see what the report will look like. You may choose to print the report from the preview screen.

Click the **Cancel** button to dismiss the **Report Page Format** box without previewing the report.

Exporting Data

To export data to a Microsoft Excel spread sheet, choose **Export** from the **File** menu. This will open the **Save As** dialog box to allow you to choose the location for saving the currently active data set in Microsoft Excel spreadsheet format.

Care and Maintenance

Your L2000DX is designed for ease of use and reliability and requires very little maintenance. By following the instructions outlined below, you should be able to obtain maximum life from the electrode and the instrument itself.

Changing Paper

1. Turn the L2000DX Analyzer off and remove the external power plug, if attached. Turn the analyzer over, lay flat on smooth surface and remove paper access door on bottom.
2. Remove the empty paper roll by grasping the roll in the middle with one hand. With the other hand, gently push one side of the paper bracket out away from the roll, while lifting the roll in the middle. This will free one end of the spindle. Continue lifting the roll out of the bracket until it is free.
3. Remove the paper spindle from the spent core and insert into the new roll of paper.
4. With the L2000DX Analyzer still upside down and the paper access on the right side, slide the analyzer to the edge of the table until it hangs over the edge far enough for the paper slot on the keypad to be accessible. **DO NOT ALLOW THE UNIT TO HANG TOO FAR OVER AS IT MAY FALL.**
5. Install the new paper roll into the holder with the loose end of the paper coming off the top of the roll. (Treated side must be on the top of the paper as it exits the roll.) Grasping the roll in the middle, slide the roll between the uprights of the paper holder until the ends of the spindle snap into the holes in the paper bracket. While pushing in the paper roll, it may be necessary to slide the roll of paper to one side to deflect the paper holder enough to clear the other side. Once in place, the roll should spin freely and remain on the holder.
6. The paper should now be installed in the paper holder with the free end on top of the roll. With a clean square end, fold one corner of the paper back flush with the opposite side to form a 45° point on the end. If there is not a clean square end on the paper, pull off a length of paper and tear a square edge off, along the bottom of the case, before folding the corner.
7. Place the paper flat on the circuit board with the pointed end of the paper extending over the edge of the paper slot. Position the point approximately 1 inch from the side of the slot and, while keeping the paper flat on the board, slide the paper forward so that the point goes under the front edge of the green circuit board and into the printer. Continue pushing the paper forward, while gently moving the paper from side to side, until the paper exits the front of the analyzer.
8. Gently pull the paper through from the front of the analyzer until a section of the full width of paper is exposed.
9. If the paper does not exit the front of the analyzer, remove the paper and retry from step 7 above.

10. Once the paper has been installed, replace the paper access door and turn the analyzer back over.

General Care

Do not allow the instrument to get wet. As with any electronic instrument, water is the quickest way to destroy the L2000DX's components. Store the instrument in its case when it is not in use and do not expose it to extremely humid environments.

Be careful not to spill any of the solutions on the instrument. They are all acidic and will quickly destroy the circuitry if they come into contact with it. If solutions are spilled onto the instrument, wipe it off quickly with a damp cloth. Do not store solutions in the same case with the instrument, as any leakage may cause serious damage. This is particularly important when the instrument is to be shipped by air.

When using the L2000DX where AC power is available, operate the instrument with the AC adapter. This will prolong the life of the battery and insure that the battery is always charged.

Always store the L2000DX with fully charged battery. (A completely dead battery could take approximately 6-8 hours to charge fully.)

If the L2000DX is to be stored for prolonged periods of time, it is important to periodically charge the battery. This will prolong the battery life and insure that the analyzer is always ready for use.

Protect the analyzer from static electric charges. The keypad and case are isolated from the internal circuitry and are not susceptible to static discharge. However, when connecting the electrode to the meter, under certain environmental conditions, the static discharge may reset the power management circuit. Before connecting the electrode, first touch the outer ring of the BNC connector with one hand while holding the metal connector on the electrode in the other. Then connect the electrode to the Analyzer.

The L2000DX analyzes for PCBs/Chlorinated Organics by finding the total amount of chlorine in a given sample. It is important, therefore, to keep all extraneous sources of chlorine away from the instrument and the various solutions. Take extra precaution when working near salt water or under very warm conditions when contamination by perspiration is possible. Never pour used CALIBRATION, RINSE, or EXTRACT solution back into a storage bottle as the entire bottle may become contaminated.

Electrode Care and Maintenance

The electrode is the most sensitive component of the L2000DX system. Care must be taken not to damage the sensing membrane on the tip of the electrode. If it does become damaged or contaminated, it may be possible to restore the electrode response by polishing. To polish the electrode: Remove one of the membrane polishing strips from the instrument case and place it flat on a solid surface, abrasive side up. Place one or two drops of RINSE solution or distilled water on the abrasive strip. With the electrode perpendicular to the abrasive strip, polish the electrode tip by gently moving it in a circular motion for about 30 seconds. Apply constant pressure, but do not push too hard on the electrode. When finished, soak the electrode for five minutes in rinse solution. Polishing strips can be reused several times. **NOTE: DO NOT OVER POLISH. ELECTRODES SHOULD BE POLISHED ONLY WHEN NECESSARY.**

When an electrode is not to be used for a period of more than one week or for an indefinite period, drain the filling solution from the electrode, flush the inside one or more times with distilled water, and store it dry with the protective black cap to protect the sensing membrane. Make sure to follow the procedures for restoring electrodes before using the electrode again (see **Restoring the Electrode After Extended Storage**).

Otherwise, the electrode filling solution should not be allowed to evaporate causing crystallization. For short periods of time between sample measurements including up to one week storage, maintain filling solution in the electrode and store the electrode in rinse solution. (NOTE: If a period of 12 hours [overnight] or longer elapses between measurements, drain a portion of the filling solution from the electrode, add additional filling solution to the filling hole, and start with fresh rinse solution.)

Trouble Shooting

The instrument does not turn on.

1. The battery is dead. Plug in the AC adapter and retry.
2. The power management circuit has been overloaded and is locked due to a severe static electric discharge during the connection of the electrode. Open the back of the instrument by removing the four Phillips head screws. Disconnect the battery and reconnect it. The analyzer should turn on as normal except that the time and date will have been lost and must be re-entered. Follow the procedure outline under **Electrode Care** for connecting the electrode.

The instrument turns on but the time and date have been lost.

1. The power management circuit has been overloaded and has reset. This is most likely due to a static electric discharge during the connection of the electrode. Re-enter the time and date and proceed with the operation of the instrument. Follow the procedure outline under **Electrode Care** for connecting the electrode. Check electrode output in **DIAGNOSTIC Mode**.
2. The battery has been disconnected and reconnected, resetting the power management circuit. Proceed as above.

The instrument turns off when plugging in the electrode.

1. A large static electric discharge has overloaded the power management circuit. Turn Analyzer on in the normal manner. Power-up will be to the time and date screen. Follow the procedure outline under **Electrode Care** for connecting the electrode.

The instrument does not provide a millivolt reading, in “DIAGNOSTICS”, after the electrode has been plugged in.

Check the electrode to verify that it contains the filling solution. If it is empty or low, refill the electrode as described in: **Restoring the Electrode After Extended Storage.**

1. Make sure that the bottom half inch (centimeter) of the electrode is completely immersed in the rinse solution.
2. Check the cable for loose connections.

The millivolt reading will not exceed 140 mV.

1. Replace the RINSE solution, and swirl the electrode for several seconds before letting the reading stabilize.
2. Replace the filling solution in the electrode as described in: **Restoring the Electrode After Extended Storage.**
3. Polish the end of the electrode. Remove one of the membrane polishing strips from the instrument case and place it flat on a solid surface, abrasive side up. Place one or two drops of RINSE solution or distilled water on the abrasive strip. With the electrode perpendicular to the abrasive strip, polish the electrode tip by moving it in a circular motion for about 30 seconds. Apply constant pressure, but do not push too hard on the electrode.
4. DO NOT OVER POLISH!! ELECTRODES SHOULD BE POLISHED ONLY WHEN NECESSARY.

The electrode will not calibrate.

1. During calibration the output from the electrode is checked. If it is outside the acceptable range, the electrode will not calibrate and the program will jump to “DIAGNOSTICS”. In this mode check the output of the electrode. It should be between 50 mV and 75 mV. To obtain the proper millivolt output, the tip of the electrode must be immersed in calibration solution. If the electrode contains adequate filling solution, and is immersed in **fresh** calibration solution and allowed to equilibrate, the output should reach the correct level.
2. The electrode will not calibrate, even after it has equilibrated:
 - a. Change the calibration solution and refill the electrode as described in the **Restoring the Electrode After Extended Storage.**
 - b. If this does not solve the problem, polish the electrode as outlined in **Care and**

Maintenance.

- c. If these procedures do not work, the electrode may need to be replaced. Contact Dexsil for return information.

Insufficient quantity of solvent recovered from soil extraction.

Some soils are extremely dry or may contain a large percentage of organic material which can absorb enough extraction solvent so that there is less than the required amount of solvent available to complete the test. When soils of this type are being tested, five grams of sample instead of ten may be used. The final reading is then doubled or the Method is modified so that the **Sample Size Correction** is changed to **twice** its normal value. For instance, if, after weighing in five grams of soil, the final reading on the L2000DX is 35 ppm, the actual result for that sample is 70 ppm. Make sure to use the full quantity of extraction solvent and follow the instructions as you would for any sample. NOTE: This technique causes a loss of precision and should not be used unless absolutely necessary.

Error Messages

CAL ERROR: This message is generated during calibration if the electrode output is not between 50 mV and 75 mV. If this message occurs:

1. Check solutions and change if not correct or not fresh.
2. Check electrode output and refill with fresh fill solution if necessary.

CHECK DRIFT: This message indicates that there is excessive drift in the electrode output either during a measurement or calibration. If this message occurs during the measurement of an unknown, the best estimate of the analytical result will be displayed below the warning. This number is for reference only, it may not be reliable. The sample must be re-analyzed to obtain an acceptable result. If this message occurs during a calibration, the electrode mV output will appear below the warning. If the warning appears, check the following:

1. Check the electrode performance as described under **Restoring the Electrode After Extended Storage**. Follow the steps for electrode draining and refilling, then recheck the electrode output. If this message occurs during calibration, the electrode is most likely damaged. See above under **The electrode will not calibrate**.
2. Check electrode leakage - The electrode is designed to leak a small amount of filling solution through the gap between the sensing pellet and the epoxy body. If the leak rate is too slow or too fast the performance of the electrode may be adversely affected. The electrode leak rate should be between 0.2 cm and 3 cm in 24 hours (as measured from the filling hole to the top of the fill solution).

3. Check for sample contamination. Some samples contain high levels of sulfur, heavy metals, waste oil, or other organics that may carry over to the final extract. If these compounds come into contact with the electrode, they can poison the sensing element. The output from the electrode will deteriorate with repeated exposure to these contaminants. If repeated samples cause a drift error, but the electrode checks out with the standard solutions, check for sample contamination.

CHECK ELECTRODE: This message indicates that the electrode output has exceeded 180 mV. If this message appears, the electrode has been damaged or the wrong electrode has been attached to the L2000DX analyzer. Check for the correct electrode then follow steps for restoring an electrode.

HIGH: This message indicates that an unknown reading is above 5000 ppm in analyte concentration. This message only appears during an unknown measurement. If this message occurs, re-analyze the sample using a smaller sample size.

LOW: This message indicates that an unknown reading has resulted in a negative analyte concentration. This can be caused by either an electrode malfunction or an improper blank value used, i.e., a large blank value not representative of the true blank. If this message occurs, check the blank value used or check the electrode function as described above. If the electrode checks out, investigate possible co-contaminants in the sample that may have adversely affected the electrode.

Appendix A: Additional Information Available from Dexsil

- DTR-10-01 "Alternative Methods of PCB Analysis", Stephen Finch, Dexsil Corporation; Generators Journal, Winter 1990.
- DTR-10-02 "One Example Where Chromatography May Not Necessarily Be the Best Analytical Method", S.R. Finch, D.A. Lavigne-Dexsil Corporation, R.P.W. Scott, Ph.D.-Georgetown University; Journal of Chromatographic Science-July 1990.
- DTR-11-01 "A Comparison of Current PCB Analytical Techniques", Stephen Finch-Dexsil Corporation; PCB Forum, 3rd International Conference for the Remediation of PCB Contamination, 1991.
- DTR-11-02 "Case Study of a New Field Screening Tool for Delineating Soil PCB Contamination", Mark B. Williams, PE and John S. Flickinger-Dames & Moore (Madison, WI), Joseph E. Shefchek, CHMM-Wisconsin Power & Light (Madison, WI), E. Jonathan Jackson, CHMM-Haliburton NUS Environmental Corp. (Aiken, SC); Proceedings: 1991 EPRI PCB Seminar.
- DTR-11-03 "PCB Determination, Simple/Low Cost or Complex/Expensive, Which Method is the Most Reliable in the Field?", S. Finch, pp. 45-1 to 45-4; Proceedings: 1991 EPRI PCB Seminar
- DTR-12-01 "Application of a New PCB Field Analysis Technique for Site Assessment", Roger D. Griffin-Griffin Environmental; Proceedings of Hazmacon '92 March-1992.
- DTR-12-02 "Available Options for the Analysis of PCBs", Stephen Finch; Environmental Science and Engineering p. 15., Feb.-March.
- DTR-13-01 "Electrochemical Method for Surface Testing of PCB Contaminated Electrical Equipment", Stephen Finch; 7th Annual Industry and PCB Forum, June 1993, Canadian Electricity Forum.
- DTR-13-02 "A Comparison of Popular Field Screening Methods for PCB Contamination in Soil", Alvia Gaskill-Environmental Reference Materials, 1993 EPRI PCB Seminar.
- DTR-14-02 "Comparison of the Response of PCB Test Methods to Different PCB Aroclors", Stephen Finch-Dexsil Corporation; Proceedings of "The Tenth Annual Waste Testing and Quality Assurance Symposium", July 11-15, 1994 Arlington, VA.
- DTR-14-03 "Effect of Transformer Oil, Petroleum Hydrocarbons and Inorganic Salt as Interferences in Field Screening for PCB Contamination of Soil", Alvia Gaskill; Proceedings of "The Tenth Annual Waste Testing and Quality Assurance Symposium", July 11-15, 1994 Arlington, VA.
- DTR-17-01 "Determination of Chlorinated Hydrocarbon Concentrations in Soil Using a Total Organic Halogen Method", T.B. Lynn, J.C. Kneeece, B.J. Meyer, A.C. Lynn; Presented at the 13th Annual Waste Testing & Quality Assurance Symposium, July 6-9, 1997, Arlington, VA.
- DTR-17-02 "Improved Extraction Efficiency of Polychlorinated Biphenyls From Contaminated Soil Using a Total Halogen Screening Method", W.S. Schutt-Young, Ph.D., A.C. Lynn, T.B. Lynn, Ph.D., B.J. Meyer, M.J. Krumenacher; Presented at "EnvirACS '97" held at the 13th Annual Waste Testing & Quality Assurance Symposium, July 7-9, 1997, Arlington, VA.
- DTR-18-03 "Electrochemical Technique/Ion Specific Electrode Dexsil Corporation L2000 PCB/Chloride Analyzer", A.B. Dindal, S. Billetts, Environmental Technology Verification Report, US-EPA, Office of Research and Development, Washington, D.C., EPA/600/R-98/109, August 1998

- DTR-20-01 PCB Detection Technology Dexsil Corporation L2000DX Analyzer, A.B. Dindal, C.K. Bayne, E.N. Koglin, Draft Environmental Technology Verification Report, US-EPA Office of Research and Development, Washington, D.C. Report, December 2000
- DTR-21-01 "Analysis of Water for PPB Range Chlorinated Organics Using a Total Organic Chlorine Analyzer," Theodore B. Lynn, Ph.D., Mary Kate Boggiano, Larry M. Sacramone, David L. Balog, Andrew C. Lynn, Dexsil Corporation, Presented at the Waste Testing and Quality Assurance Symposium 2001, August 13-16, 2001, Arlington, VA
- DTR-21-02 "Low Level Detection of PCE in Monitoring Well Samples Using a Total Organic Chlorine Based Field Method," Theodore B. Lynn, Ph.D., Dexsil Corporation, Keith A. Wright, Camino, California, Presented at the Waste Testing and Quality Assurance Symposium 2001, August 13-16, 2001, Arlington, VA
- DTP-09-01 "Accurate On-Site Analysis of PCBs in Soil, A Low Cost Approach", Deborah Lavigne-Dexsil Corporation.
- DTP-09-02 "Field Test Kit for Quantifying Organic Halogens in Water and Soil", Deborah Lavigne-Dexsil Corporation.
- DTP-11-01 "PCB Analysis by Gas Chromatography-What do the Numbers Mean? 1991", Stephen Finch-Dexsil Corporation.
- DMR-16-01 EPA Method 9078 "Screening Test Method for Polychlorinated Biphenyls in Soil", 3rd edition SW 846- Test Methods for Evaluating Solid Waste, Physical/Chemical Methods, June 1997; Federal Register Vol. 62, No. 114, 6/13/97, Rules & Regulations.

Appendix B: L200DX System Methods Table

Compound	Blank Subtract	%Chlorine	Size Multiplier	Extraction Multiplier	Matrix	Units	Analyte Label	Method Name
Aroclor 1242	yes	42	1.13	1.11	Oil	ppm	AROCLOR 1242	1242 OIL
Aroclor 1242	yes	42	1	1.33	Soil	ppm	AROCLOR 1242	1242 SOIL
Aroclor 1242	yes	42	1	1.1	Soil	ppm	AROCLOR 1242	2 STEP 1242
Aroclor 1242	yes	42	1	1	Wipe	Fg/100scm	AROCLOR 1242	1242 WIPE
Aroclor 1242	yes	42	1	1.25	Water	ppm	AROCLOR 1242	1242 WATER HIGH
Aroclor 1254	yes	54	1.13	1.11	Oil	ppm	AROCLOR 1254	1254 OIL
Aroclor 1254	yes	54	1	1.33	Soil	ppm	AROCLOR 1254	1254 SOIL
Aroclor 1254	yes	54	1	1.1	Soil	ppm	AROCLOR 1254	2 STEP 1254
Aroclor 1254	yes	54	1	1	Wipe	Fg/100scm	AROCLOR 1254	1254 WIPE
Aroclor 1254	yes	54	1	1.25	Water	ppm	AROCLOR 1254	1254 WATER HIGH
Aroclor 1260	yes	60	1.13	1.11	Oil	ppm	AROCLOR 1260	1260 OIL
Aroclor 1260	yes	60	1	1.33	Soil	ppm	AROCLOR 1260	1260 SOIL
Aroclor 1260	yes	60	1	1.1	Soil	ppm	AROCLOR 1260	2 STEP 1260
Aroclor 1260	yes	60	1	1	Wipe	Fg/100scm	AROCLOR 1260	1260 WIPE
Aroclor 1260	yes	60	1	1.25	Water	ppm	AROCLOR 1260	1260 WATER HIGH
Askarel A	yes	99	1.13	1.11	Oil	ppm	ASKAREL A	ASKAREL A OIL
Askarel A	yes	99	1	1.33	Soil	ppm	ASKAREL A	ASKAREL A SOIL
Askarel A	yes	99	1	1.1	Soil	ppm	ASKAREL A	2 STEP ASKAREL A
Askarel A	yes	99	1	1	Wipe	Fg/100scm	ASKAREL A	ASKAREL A WIPE
Askarel A	yes	99	1	1.25	Water	ppm	ASKAREL A	ASK A WATER HIGH

Compound	Blank Subtract	%Chlorine	Size Multiplier	Extraction Multiplier	Matrix	Units	Analyte Label	Method Name
DDT	yes	50	1	1.91	Soil	ppm	DDT	DDT SOIL
Toxaphene	yes	68	1	1.54	Soil	ppm	TOXAPHENE	TOXAPHENE SOIL
Chlordane	yes	69	1	1.42	Soil	ppm	CHLORDANE	CHLORDANE SOIL
PCP*	yes	67	1	2.54	Soil	ppm	PCP	PCP SOIL
Trichloro ethylene	yes	81	1	1.00	Soil	ppm	TRICHLOR	TRICHLOR SOIL
Trichloro ethylene	yes	81	10	1.86	Water	ppb	TRICHLOR	TRICHLOR WATER
1,1,1 Tri-chloro ethane	yes	80	10	2.03	Water	ppb	111 TRICHLORETHANE	111 TRICHLOR WATER
Tetrachloro ethylene	yes	86	1	1.00	Soil	ppm	TETRACHLOR	TETRACHLOR SOIL
Tetrachloro ethylene	yes	86	10	1.89	Water	ppb	TETRACHLOR	TETRACHLOR WATER
Methylene Chloride	yes	83	10	13.0	Water	ppm	METHCHLORIDE	METHCHLOR WATER
Vinyl Chloride	yes	57	10	5.36	Water	ppb	VINYLCHLORIDE	VINYLCHLOR WATER
Dichloro ethylene	yes	73	10	3.46	Water	ppb	DICHLORETHYLENE	DICHLOR WATER
Chloride	yes	100	1	1	None	ppm	CHLORIDE	CHLORIDE

* Requires two-step solvent system with filter omitted.

Appendix C: Technical Data

Physical

Size:	w = 9" (230mm) d = 9.5" (240mm) h = 4.25" (110mm)
Weight: Shipping Weight:	5 lbs. 12 oz. (2.6 kg) 17 lbs. (7.75 kg)
Case: Keypad:	Painted Aluminum 16 Position UV-Resistant Polyester Membrane Keypad

Electrical

Battery Power:	Internal 8V Gel Cell (3 Days of Operation on Full Charge)
Line Power:	12 W, 115V or 220V Wall Transformer
Charging:	Internal IC Controlled Charging Circuit
Power Management:	Automatic Shut-Off After 15 Minutes of Non-Use With Low-Power Warning and Shut-Off

Digital

Processor:	AM188EM
A/D Converter:	24 Bit Auto-Ranging
Memory:	
Method Storage:	28 Pre-programed Methods + Up to 22 User Defined Methods
Data Storage:	1800 pts

Input

Range:	± 300 mV
Electrode:	BNC Connector (Back Panel) Electrode Type: ORION 96-17B Combination Chloride Electrode

Output

Display:	Backlit, 2 x 16 LCD, 0.32" Character Height
Printer:	40 Character Onboard Thermal Printer (Paper Re-Order PN: LP-THP-01)
External Printers:	Canon BJC-4300, BJC 250, and BJ-200ex; Epson ActionLaser 1400, and Stylus 740, HP DeskJet 870Cse, and LaserJet 4000T
Parallel Printer Port:	25-pin Female Connector (bidirectional)
RS-232:	Data Upload to PC (L2000DX Data Manager required)

Operating Environment

Temperature:	55 °F - 100 °F (13 °C - 38 °C)
Humidity:	85% (non-condensing)
Sunlight:	Do Not Operate With Electrode Exposed to Direct or Indirect Sunlight

Appendix D: Program Flow Chart

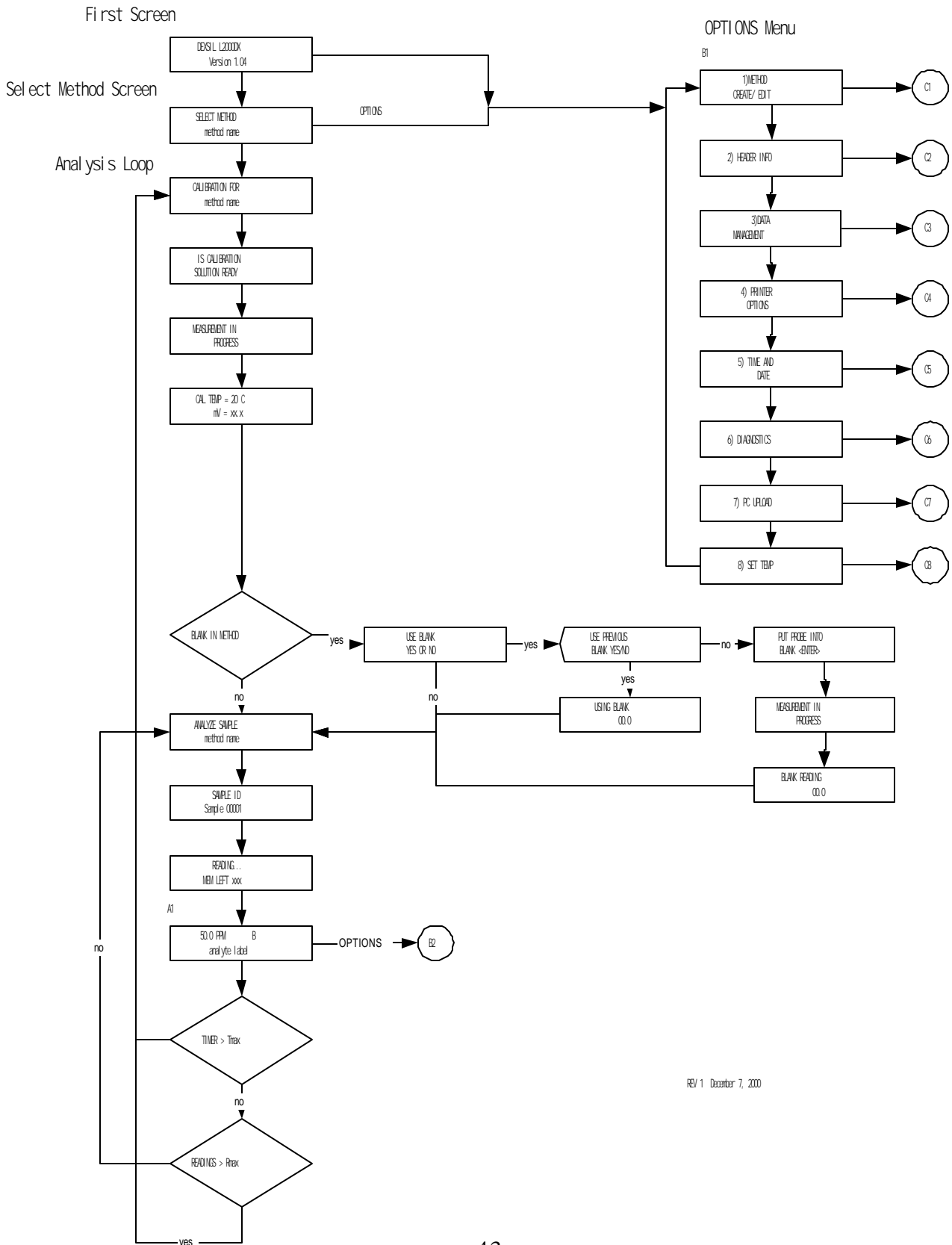

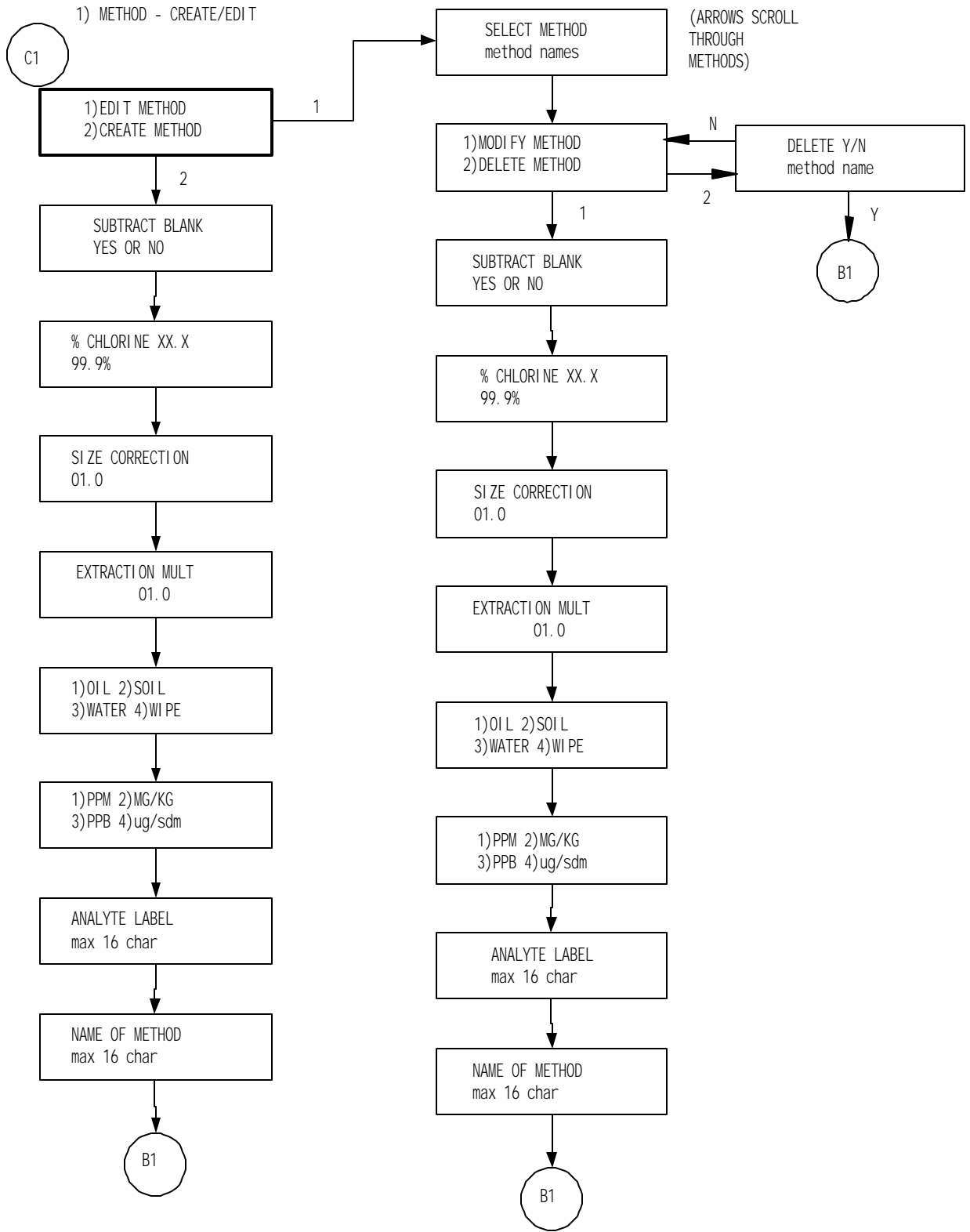

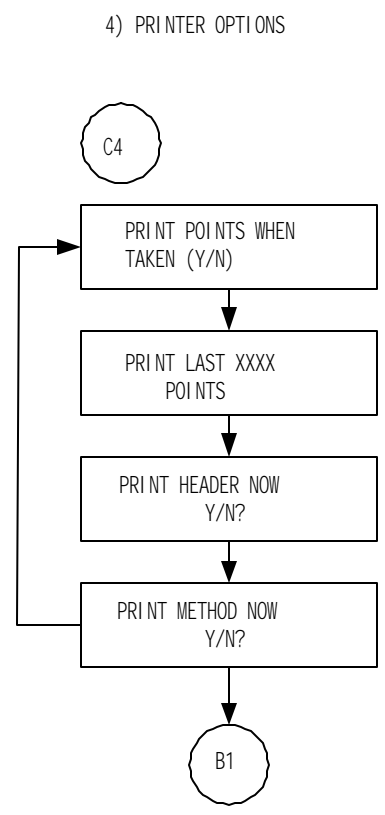
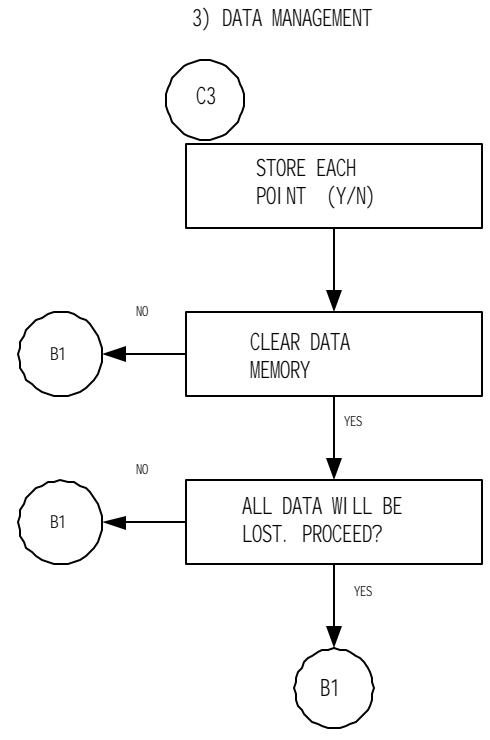
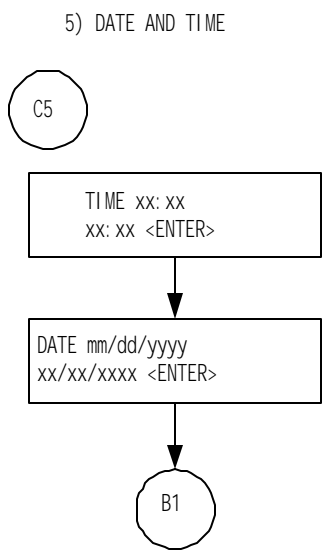
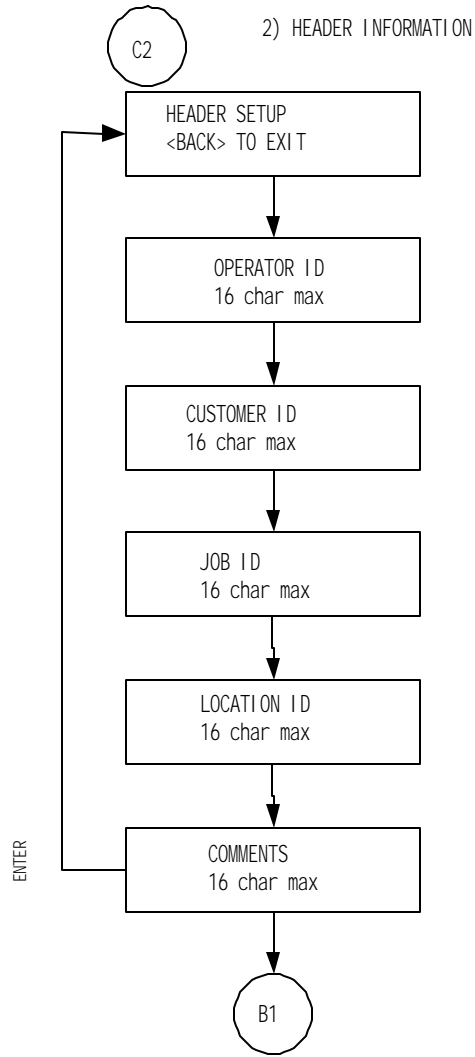

REV 2, December 7, 2000

6) DIAGNOSTICS

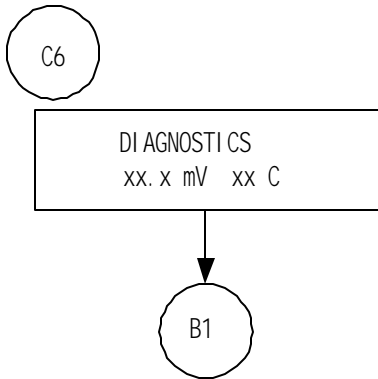

7) PC UPLOAD

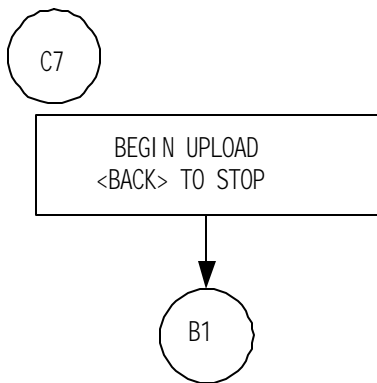

8) SET TEMP

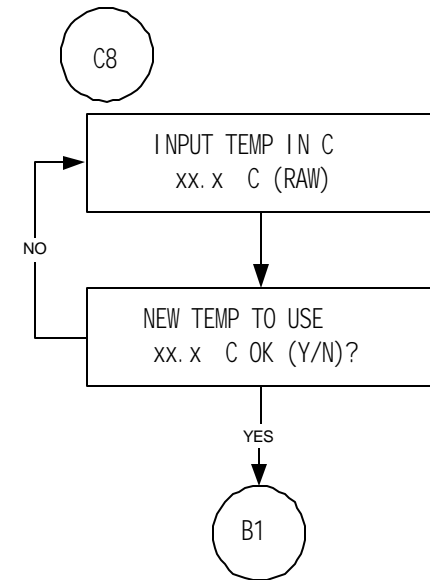

METHOD INFORMATION

B2

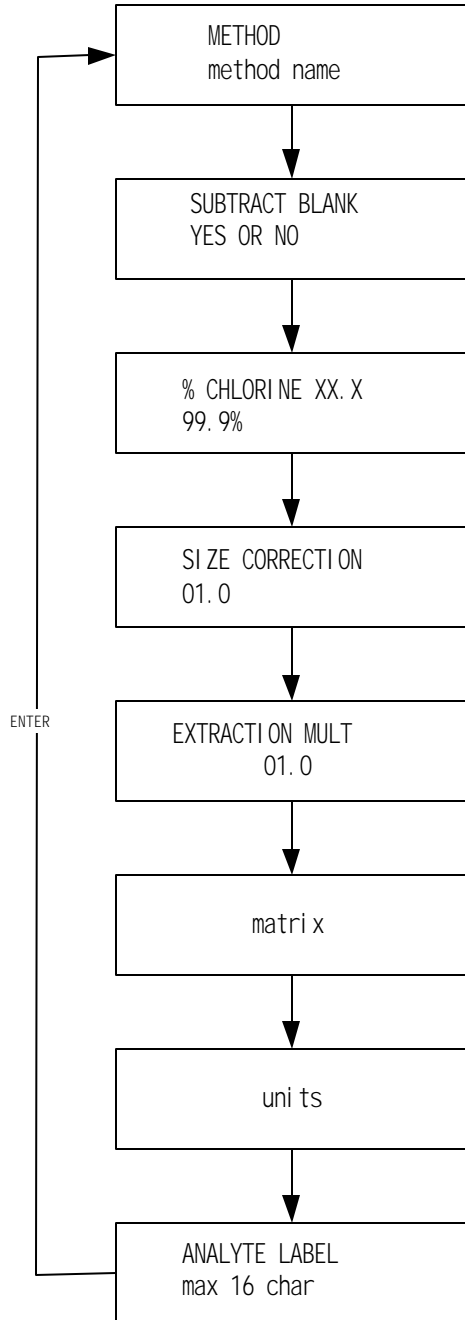

ENTER SCROLLS THROUGH
METHOD. BACK RETURNS
TO A2.

DEXSIL CORPORATION
L2000DX ANALYZER
ONE YEAR LIMITED WARRANTY

DEXSIL CORPORATION warrants the L2000DX Analyzer against defects in material or workmanship for a period of one year from the date of purchase. During the warranty period, any product which is determined by DEXSIL to be defective in material or workmanship and returned to DEXSIL as specified below, will be, as the exclusive remedy, repaired or replaced at DEXSIL's option.

The cost of repair or replacement is included, shipping costs are not and are to be paid by the customer.

In the event that an L2000DX Analyzer is suspected to be defective contact a DEXSIL representative at the address below to obtain a return authorization:

DEXSIL CORPORATION
ONE HAMDEN PARK DRIVE
HAMDEN, CT 06517
TEL:(203) 288-3509
FAX:(203) 248-6523

Upon return of the unit it will be inspected and a determination will be made as to whether the product is defective. If defective, arrangements will be made for repair or replacement without charge.

THE WARRANTY SET FORTH ABOVE IS EXCLUSIVE AND NO OTHER WARRANTY, WHETHER WRITTEN OR ORAL, IS EXPRESSED OR IMPLIED. DEXSIL SPECIFICALLY DISCLAIMS THE IMPLIED WARRANTIES OF MERCHANTABILITY AND FITNESS FOR A PARTICULAR PURPOSE.

DEXSIL CORPORATION IS NOT LIABLE FOR INDIRECT OR CONSEQUENTIAL DAMAGES IN CONNECTION WITH THE USE OF THE PRODUCT.

Some states do not allow the exclusion or limitation of incidental or consequential damages, so the above limitation or exclusion may not apply to you.

This Warranty applies only to parts or components which are defective and does not cover repairs necessary due to normal wear, misuse, or accidents.

All warranty repairs reimbursable under this warranty must be performed by DEXSIL CORPORATION or its representative using approved replacement parts.

Repairs or attempted repairs by anyone other than a DEXSIL representative are not reimbursable under this warranty. In addition, these unauthorized repair attempts may result in additional malfunctions, the correction of which is not covered by warranty.

This warranty gives you specific legal rights, and you may also have other rights which vary from state to state.